

STATEMENT

We, Polestar hereby certify that the material/quality/strength of the springs listed below correspond to the parts used in serial production of the Polestar 2 cars. They also fulfil the Polestar quality. Please see attached drawings for detailed information.

Attached drawings:

Polestar 2 front spring

Drawing number 34076946

Polestar 2 rear spring

Drawing number 34076895

Polestar

Susanne Månsson

Head of Quality

Polestar Performance AB

February 9, 2024

Polestar 2 front spring

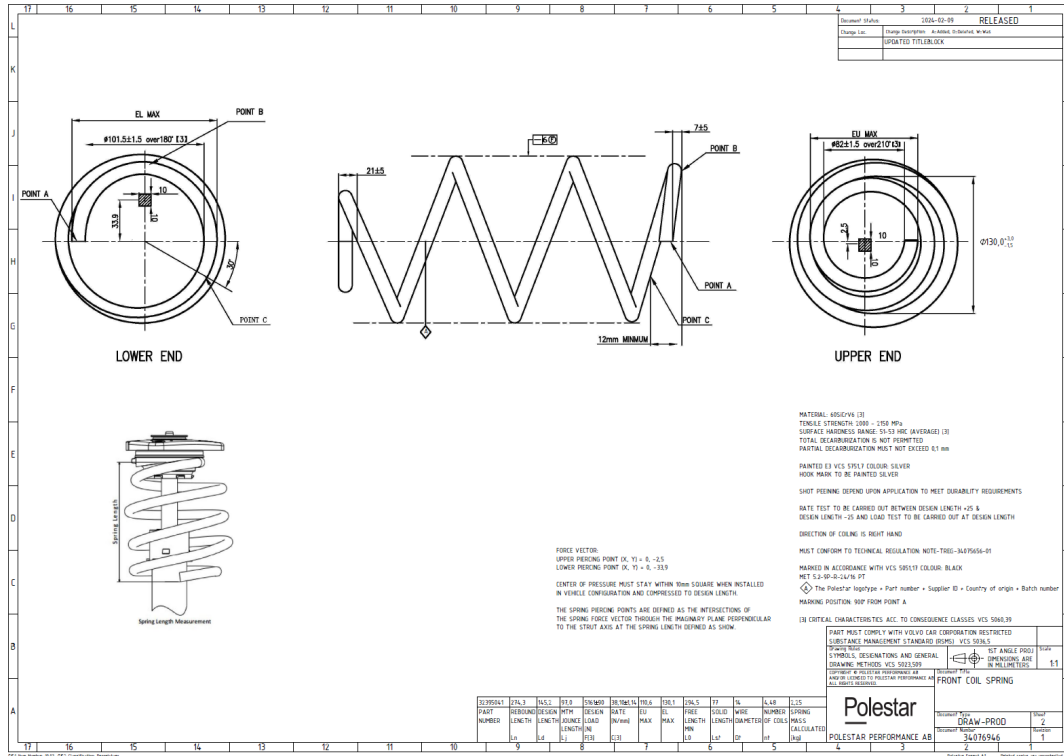

Polestar 2 rear spring

